

TyphoonTM



Real Aussie Pools
Steve Lothian
1300 722 009
0401 811 965

Swimming Pool Pump

Heavy duty, reliable pool pumps
delivering optimum performance
in your pool or spa

Guarantee
3 years

T Series



C Series
(Formerly Cyclone)

Features & Benefits

- Designed for durability and long life using corrosion resistant, UV stabilised materials
- Self priming pump for trouble-free operation and air handling
 - Built in thermal overload protection protects motor in the event of low voltage or jammed pump
- Strong performance and high flow provides optimum water circulation
- Stainless steel pump shaft suited for salt water pools
- Reinforced pump base keeps the motor high and dry for corrosion protection
- Large leaf basket handles large leaves and debris with ease
- Large clear leaf basket lid provides easy visual inspection of contents
- Barrel union connections for easy installation
- Range of sizes to suit domestic pools and solar applications

MONARCH
S E R I E S
BY DAVEY WATER PRODUCTS

davey.com.au

Typhoon™

Pool Pump

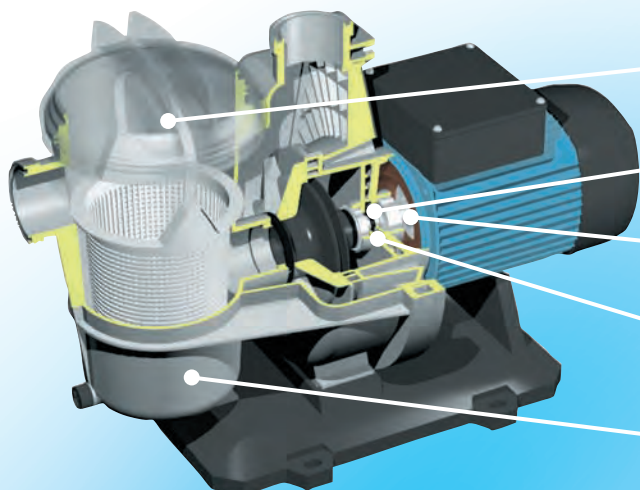

- Large, easy to remove, leaf basket cover for convenience and easy cleaning
- Carbon / Ceramic mechanical seal
- Stainless steel motor shaft for corrosion resistance in salt water pools
- Impeller made of glass-filled Noryl® for high abrasion resistance
- Corrosion resistant body, foot and diffuser from glass-filled polypropylene construction.

ELECTRICAL DATA							
Model – Typhoon	C50M	C75M	C100M	C150M	T150M	T200M	T300M
Voltage (V)	220-250						
Supply Frequency/Phase	50Hz / 1						
Run Current (A)	3.3	5.0	5.8	6.6	7.9	9.2	10.8
Motor Input Power (W)/hp	800/1	1100/1.6	1200/1.9	1600/2	1900/2.5	2200/2.9	2800/3.5
Motor Output Power (W)/hp	440/0.6	550/0.7	750/1	1100/1.5	1100/1.5	1500/2	2200/2.9
RPM	2900						
Enclosure Class (IP)	55						
Insulation Class	F						
Approval No.	W2442						

OPERATING LIMITS	
Water Temperature	Max 35°C
Ambient Temperature	Max 50°C

DIMENSIONS (mm)									
Model	A	B	C	D	E	F	Inlet P.V.C. (mm)	Outlet P.V.C. (mm)	Net Weight (Kg)
C50M	532	330	238	345	225	262	40/50	40/50	9.4
C75M									10.4
C100M									11.4
C150M									13.5
T150M									18
T200M	612	429	268	397	295	284			21
T300M 15A									23

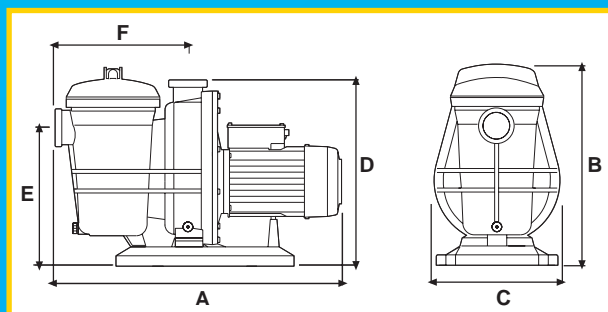
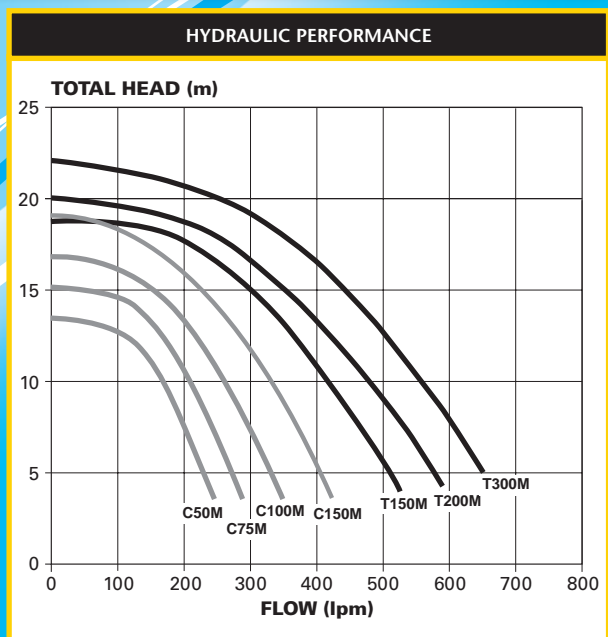

Datasheet Disclaimer: All details in this leaflet are accurate at the time of printing. This literature is not a complete guide to product usage. Further information is available from your Monarch Series dealer, Davey Customer Service Centre and from the relevant product Installation & Operating Instructions. This datasheet must be read in conjunction with the relevant Installation & Operating Instructions and all applicable statutory requirements. Product specifications may change without notice. © Davey is a registered trademark of Davey Water Products Pty Ltd. © Davey Water Products Pty Ltd 2010.



Davey Water Products Pty Ltd
Member of the GUD Group
ABN 18 066 327 517

AUSTRALIA
Head Office and Manufacturing
6 Lakeview Drive,
Scoresby, Australia 3179
Ph: +61 3 9730 9222
Fax: +61 3 9753 4100
Website: davey.com.au

Customer Service Centre
Ph: 1300 369 100
Fax: 1300 369 119
E-mail: sales@davey.com.au

NEW ZEALAND
7 Rockridge Avenue,
Penrose, Auckland 1061
Ph: +64 9 570 9135
Fax: +64 9 527 7654
E-mail: sales@daveynz.co.nz
Website: daveynz.co.nz

Customer Service Centre
Ph: 0800 654 333

REST OF WORLD
6 Lakeview Drive,
Scoresby, Australia 3179
Ph: +61 3 9730 9121
Fax: +61 3 9753 4248
E-mail: export@davey.com.au
Website: davey.com.au

